



# GOVERNMENT COLLEGE OF ENGINEERING, KARAD

(An Autonomous Institute of Govt. of Maharashtra)

VIDYANAGAR, KARAD, 415124 DIST SATARA  
Phone – ( 02164 ) 326632, 272414/15 Fax No. – ( 02164 )271713  
Website : [www.gcekarad.ac.in](http://www.gcekarad.ac.in)  
Email : [principalgcekarad@gmail.com](mailto:principalgcekarad@gmail.com)

GCEK/Civil works/Refurbishment/2018-19/

Date: 16/08/2018

## INVITATION FOR TENDER FOR “Proposed refurbishment of Chemistry laboratory at Govt. College of Engg., Karad.”

Dear Sirs,

### Sub : Invitation of tender for “Proposed refurbishment of Chemistry laboratory at Govt. College of Engg., Karad.”

1. You are invited to submit your most competitive quotation for the following works:-

Brief Description of the Works	Approximate value of Works (Rs.)	Period of Completion (In Days)
“Proposed refurbishment of Chemistry laboratory at Govt. College of Engg., Karad.”	8,91,677 /- ( Excluding G.S.T.)	60

2. Government college of Engineering Karad, which is an autonomous society registered under the Societies Registration Act.
3. To assist you in the preparation of your quotation, we are enclosing the following:
- Layout Drawings of the works;
  - Detailed Bill of Quantities, with estimated rates and prices;
  - Technical Specifications;
  - Instructions to Bidders
4. You are requested to provide your offer latest by 16:00 hrs. on 01 September 2018.
5. Quotations will be opened in the presence of BWC members and Principal at 16:00 AM/PM on 01 September 2018 in the office of Principal, GCOE, Karad.
6. We look forward to receiving your quotations and thank you for your interest in this project.

Sd/-

Name : (Dr. A.T.Pise)  
Principal,  
Government College of Engineering, Karad

Tel. No: 02164 272415

Fax No. 02164271713

## Instructions to Bidders

### SECTION - A

**1. Scope of Works:**

The **Government College of Engineering, Karad** invites quotations for the construction of works as detailed in the table given below

Brief Description of the Works	Approximate value of Works (Rs.)	Period of Completion (In Days)
<b>“Proposed refurbishment of Chemistry laboratory at Govt. College of Engg., Karad.”</b>	<b>8,91,677 /- ( Excluding G.S.T.)</b>	<b>60</b>

The successful bidder will be expected to complete the works by the intended completion date specified above.

**2. Qualification of the bidder:** The bidder shall provide qualification information which shall include:-

- (a) Should have satisfactorily completed as a prime contractor at least one similar work of value not less than Rs. 3,00,000 in the last three years
- (b) Income tax clearance certificate from the concerned IT circle, preferably for last 3 years;
- (c) Report on his financial standing;
- (d) Should have recognized Government registration as a Government contractor.

**3. Bid Price**

- a) The contract shall be for the whole works as described in the Bill of quantities, drawings and technical specifications. Corrections, if any, shall be made by crossing out, initialling, dating and re writing.
- b) All duties, taxes and other levies payable by the contractor under the contract shall be included in the total price.
- c) The rates quoted by the bidder shall be fixed for the duration of the contract and shall not be subject to adjustment on any account.
- d) The rates should be quoted in Indian Rupees only.

**5. Submission of Tender**

**5.1** The bidder is advised to visit the site of works at his own expense and obtain all information that may be necessary for preparing the quotation.

**5.2** Each bidder shall submit only one quotation.

**5.3** The quotation submitted by the bidder shall comprise the following :-

- (a) Quotation in the format given in Section B.
- (b) Signed Bill of Quantities ; and
- (c) Qualification information form given in Section B duly completed.

**5.4** The bidder shall seal the quotation in an envelope addressed to the (Purchaser). The envelope will also bear the following identification:-

- Quotation for Proposed refurbishment of Chemistry laboratory at Govt. College of Engg., Karad. (Name of the Contract)
- Do not open before **16:00 01 September 2018**. (Time and date of quotation opening).

5.5 Quotations must be received in the office of the **Government College of Engineering, Karad.** (Employer) not later than the time and date given in the letter of invitation. If the specified date is declared a holiday, quotations shall be received upto the appointed time on the next working day.

5.6 Any quotation received by the **Government College of Engineering, Karad.** (Employer) after the deadline for submission of quotations will be rejected and returned unopened to the bidder.

**6. Validity of Quotation**

Quotation shall remain valid for a period not less than **60** days after the deadline date specified for submission.

**7. Opening of Quotations**

Quotations will be opened in the presence of BWC members and Principal on the date and time and at the place specified in the letter of invitation.

8. Information relating to evaluation of quotations and recommendations for the award of contract shall not be disclosed to bidders or any other persons not officially concerned with the process until the award to the successful bidder is announced.

**9. Evaluation of Quotations**

The Employer will evaluate and compare the quotations determined to be substantially responsive i.e. which

- (a) meet the qualification criteria specified in clause 3 above;
- (b) are properly signed ; and
- (c) conform to the terms and conditions, specifications and drawings without material deviations.

**10. Award of contract**

The Employer will award the contract to the bidder whose quotation has been determined to be substantially responsive and who has offered the lowest evaluated quotation price and who meets the specified qualification criteria.

10.1 Notwithstanding the above, the Employer reserves the right to accept or reject any quotations and to cancel the bidding process and reject all quotations at any time prior to the award of contract.

10.2 The bidder whose bid is accepted will be notified of the award of contract by the Employer prior to expiration of the quotation validity period.

**11. Performance Security**

Within 03 days of receiving letter of acceptance, the successful bidder shall deliver to the **Government College of Engineering, Karad** (Employer) the performance security (either a bank guarantee or a bank draft in favour of the Employer) for an amount equivalent of 3 % of the contract price.

**12. Period of Maintenance :**

The Period of Maintenance for the work is six months from the date of taking over possession or one full monsoon season whichever occurs later. During the period of maintenance, the contractor will be responsible for rectifying any defects in construction free of cost to the Employer.

.....

**SECTION -B**  
**QUALIFICATION INFORMATION**

1.1 Principal place of business: \_\_\_\_\_

1.3 Work performed as prime contractor (in the same name) on works of a similar nature over the last three years.

Project Name	Name of Employer	Description of work	Contract No.	Value of contract (Rs. Lakhs)	Date of issue of work order	Stipulated period of completion	Actual date of completion	Remarks explaining reasons for delay and work completed

Existing commitments and on-going works:

Description of Work	Place & State	Contract No. & Date	Value of Contract (Rs. Lakh)	Stipulated period of completion	Value of works remaining to be completed (Rs. Lakhs)	Anticipated date of completion
(1)	(2)	(3)	(4)	(5)	(6)	(7)

1.5 Evidence of access to financial resources to meet the requirements of working capital: cash in hand, lines of credit, etc. List them below and attach copies of support documents.

1. \_\_\_\_\_

2. \_\_\_\_\_

3. \_\_\_\_\_

**QUOTATION**

To: **Proposed refurbishment of Chemistry laboratory at Govt. College of Engg., Karad.**

<b>No.</b>	<b>Description of Item</b>	<b>Qty.</b>	<b>Rate Rs.</b>	<b>Unit</b>	<b>Amount</b>
1.	Excavation for foundation in hard murum including removing the excavated material upto distance of 50 metres beyond the building area and stacking and spreading as directed, dewatering, preparing the bed for the foundation and necessary back filling, ramming, watering including shoring and strutting etc. complete. (Lift upto 1.50 m)	0.45	132.00	Cu.m	59.40
2.	Removing cement tiles, or marble or polished shahabad floor or dado without bed concrete including stacking the materials as directed with all leads, lifts etc. complete.	220.00	24.00	Sq.m.	5280.00
3	Providing and laying vitrified matt finish tiles having size 590 mm to 605 mm x to 605 mm of 8 to 10 mm thickness and confirming IS. 15622-2006 (Group Bla) of approved make, shade and pattern for flooring in required position laid on a bed of 1:4 cement mortar including neat cement float, filling joints, curing and cleaning etc. complete. a) Flooring.	220.00	1293.00	Sq.m	284460.0 0
4.	Providing and laying vitrified matt finish tiles having size 590mm to 605 mm x to 605 mm of 8 to 10 mm thickness and confirming IS. 15622-2006 (Group Bla) of approved make, shade and pattern for flooring in required position laid on a bed of 1:4 cement mortar including neat cement float, filling joints, curing and cleaning etc. complete. b) Skirting.	10.06	1601.00	Sq.m	16106.06
5.	Providing and constructing granite kitchen platform with fixing of stainless steel sink 600 mm x 450 mm size as per detailed drawing including vertical both side polished kadappah stone 25 to 30 mm thick supports with kadappah top 35 to 40 mm thick and polished granite 16 to 20 mm top with side strips of granite at front and both sides of platform raised with two vertical granite supports 15 cm height and top granite of 75 x 40 cm including cutting, opening for sink of required size in kadappah as well as granite etc. complete. (Platform top size 5.00 m x 0.60 m and height is 0.75 m)	3.57	7223.00	Sq.m	25786.11
6.	Providing and fixing black kadappa stone as shelves 25mm. thick machine polished, extending the polish upto 20 cm width on lowerside, rounding corners, laying in position jointing with bedding cement mortar 1:4 proportion curing etc etc. complete.	8.09	825.00	Sq.m	6674.25

7.	Providing and fixing machine cut mirror polished 18 mm to 20 mm thick telephone black / Amba White / Cat bary brown / RBI red / Ocean Brown granite stone partition with rounding the edges etc. complete. One side polish.	21.96	3349.00	Sq.m	73544.04
8.	Providing core cut hole to U.C.R masonry wall.	1	500.00	No.	500.00
9.	Providing and fixing white glazed earthenware Wash Hand Basin of 55cm. x 40 cm. size including cold water pillar tap/cold and hot water pillar tap brackets, rubber plugs and brass chain, stop tap and necessary pipe connections including P.V.C. waste pipe and trap up to the outside face of the wall. Making good the damaged surface, testing etc. complete.	7	3266.00	No.	22862.00
10.	Providing and fixing C.P. sink cock with raised J" shaped swinging casted spout jaquar or equivalent make continental (CAT.NO. CON -359) including necessary sockets/ union nut etc. complete.	7	1316.00	No.	9212.00
11.	Providing, laying and fixing P.V.C. pipe of 110 mm. dia. with fittings such as bends, tees, reducers, clamps, etc. including necessary excavation, trench filling etc. complete. Including removing existing pipe line if necessary and conveying and stacking the same in PWD chowky or as directed etc. complete.	30.00	348.00	R.m	10440.00
12.	Providing and fixing on walls/ ceiling/ floor 15 mm dia. CPVC pipe with necessary fittings, remaking good the demolished portion etc. complete. Including removing existing pipe line if necessary and conveying and stacking the same in PWD chowky or as directed etc. complete.	40.00	147.00	R.m	5880.00
13.	Providing and fixing on walls/ ceiling/ floor 25 mm dia. CPVC pipe with necessary fittings, remaking good the demolished portion etc. complete. Including removing existing pipe line if necessary and conveying and stacking the same in PWD chowky or as directed etc. complete.	25.00	209.00	R.m	5225.00
14.	Non-return valve 25mm for water meter.	1	320.00	No.	320.00
15.	Dismantling stone masonry in lime or cement mortar including stacking the materials as directed with all leads, lifts etc.	5.40	205.00	Cu.m	1107.60
16.	Providing and fixing gas pipe line as per drawing.	40.00	625.00	R.m	25000.00

17.	Providing and fixing of chemistry table as per detailed drawing including following,				
	a) 19 mm plywood	194.00	1280.0	Sq.m	248320.00
	b) Decorative laminates	80.00	500.00	Sq.m	40000.00
	c) 12mm glass top for racks	6.00	1400.0	Sq.m	8400.00
	d) Adhesive, nails, handles, drawer slider, hinges etc.	Lumsum	10000	Lumsum	10000.00
	e) B.T.C. Patti	250.00	70.00	R.m	17500.00
	f) Labour				75000.00

**TOTAL COST = Rs. 8,91,676.50 /-**

**SAY TOTAL COST = Rs. 8,91,677.00 /-**

**(In words : Eight lacs ninety one thousand six hundred and seventy seven rupees only.)**

Subject : Construction of .....

Reference : Letter No.....dated.....from.....

Sir,

We offer to execute the Works described in your letter referred to above in accordance with the Conditions of Contract enclosed therewith at ..... percentage above / below the estimated rates, i.e., for a total Contract Price of - Rs.\*\* \_\_\_\_\_ [in figures]  
Rs. \_\_\_\_\_ [in words].

This quotation and your written acceptance of it shall constitute a binding contract between us. We understand that you are not bound to accept the lowest or any quotation you receive.

We hereby certify that we have taken steps to ensure that no person acting for us or on our behalf will engage in bribery.

We hereby confirm that this quotation is valid for 45 days as required in Clause 6 of the Instructions to Bidders.

Yours faithfully,

Authorized Signature : \_\_\_\_\_ Date: \_\_\_\_\_  
Name of Bidder : \_\_\_\_\_  
Address : \_\_\_\_\_



To be filled in by the Bidder, together with his particulars and date of submission at the bottom of this Form.

**Annexure-A**  
**BILL OF QUANTITIES**

Sl. No.	Description of Work	Qty.	Unit	Estimated Cost (Rs.)		Amount
				In figure	In Words	

**Gross Total Cost : Rs. ....**



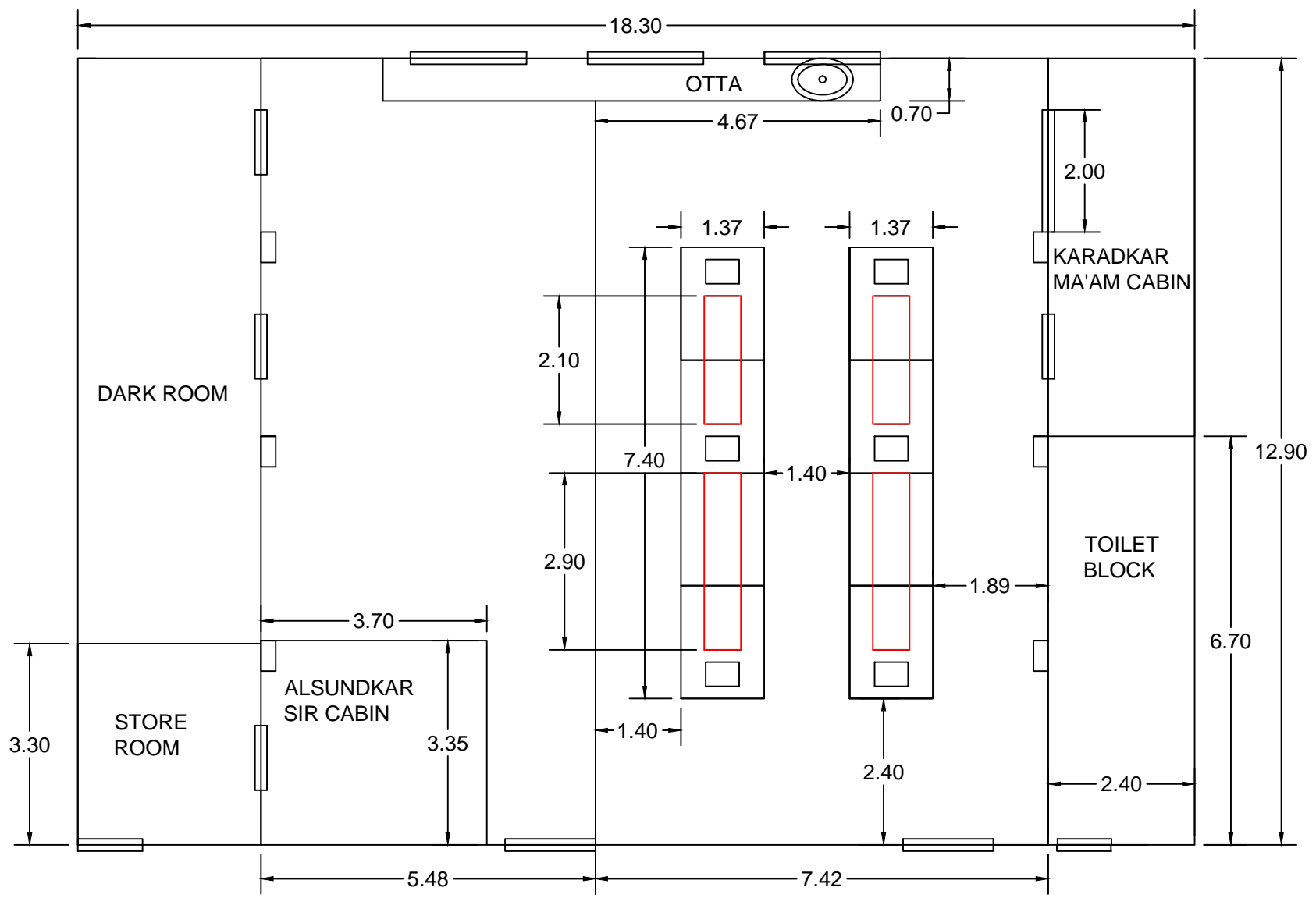

We agree to execute the works in accordance with the approved drawings and technical specifications at ..... percentage above/ below the estimated rates, i.e., for a total contract price of Rs. ....(amount in figures) (Rs. .... amount in words).

**Signature of Contractor**

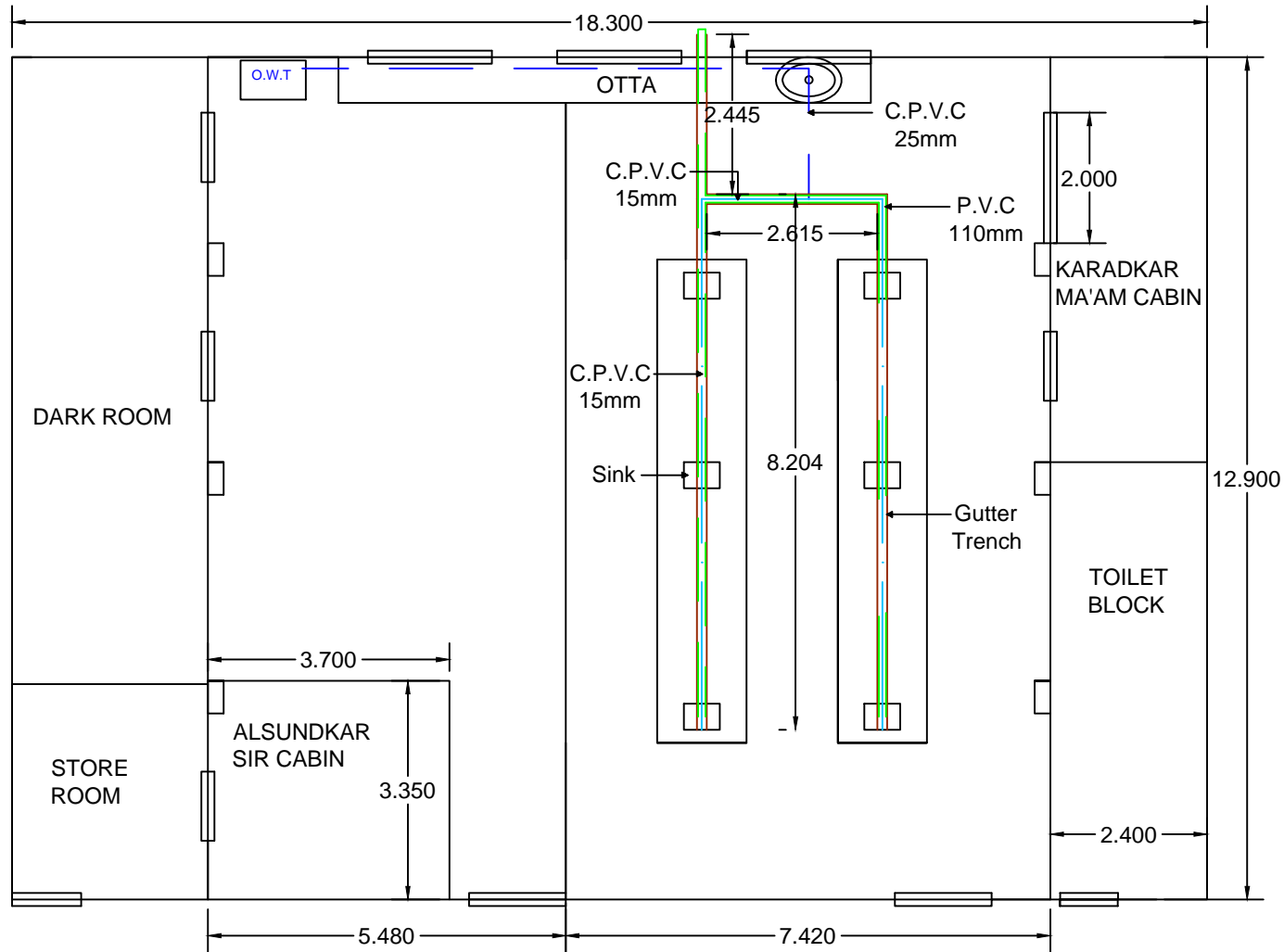

**CHEMISTRY LAB PLAN**



Sr. No.	DESCRIPTION	SYMBOL
1.	Overhead water tank	O.W.T
2.	P.V.C 110mm	
3.	C.P.V.C 25mm	
4.	C.P.V.C 15mm	
5.	GUTTER TRENCH	

**CHEMISTRY LAB - PLUMBING PLAN**

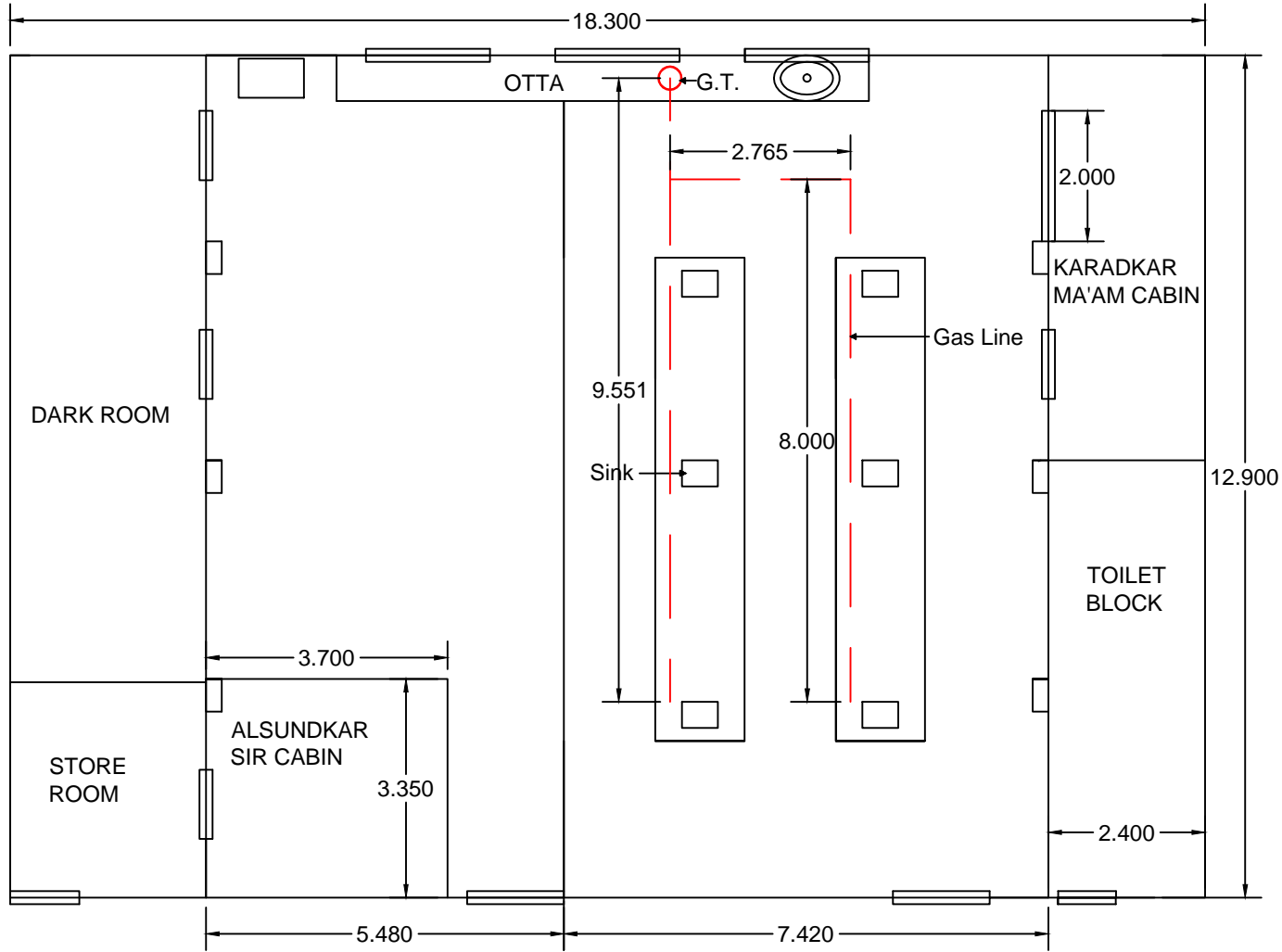

Sr. No.	DESCRIPTION	SYMBOL
1.	GAS TANK	G.T
2.	Gas Pipe line	—

**CHEMISTRY LAB - GAS LINE PLAN**

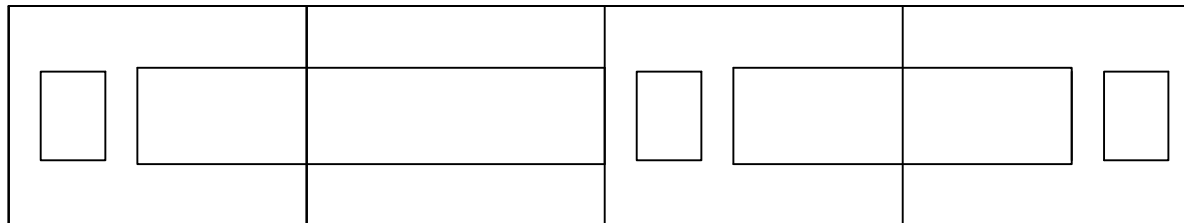
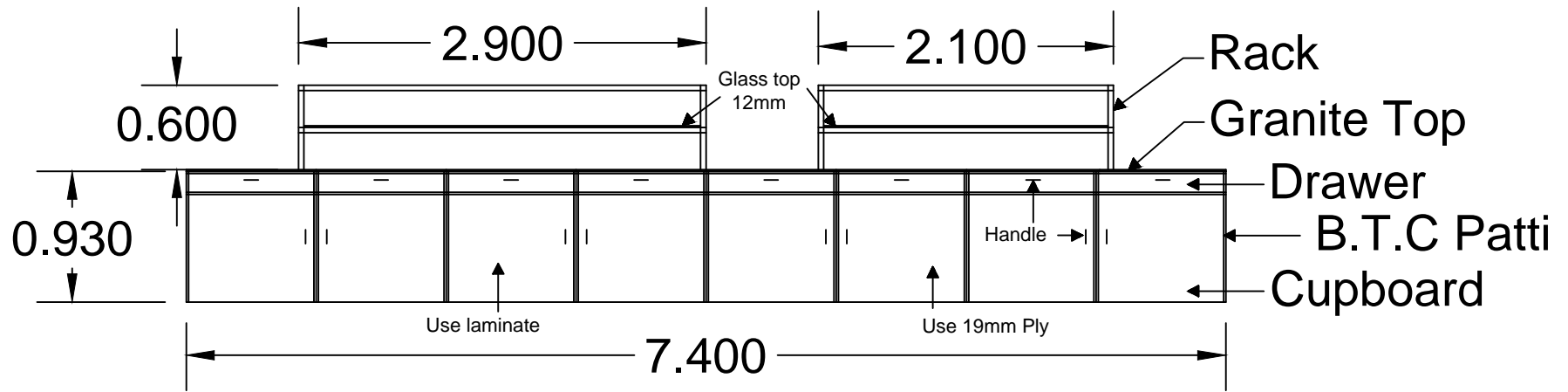

**CHEMISTRY LAB -TABLE SECTION**